

# Instruction Manual

# **MAKO** Tools

## **FINISHING SANDER**

Model SROM 1185



*Our tool range has you covered for DIY. Whatever the job, make light work of it with MAKO tools.*

**Product Features:**

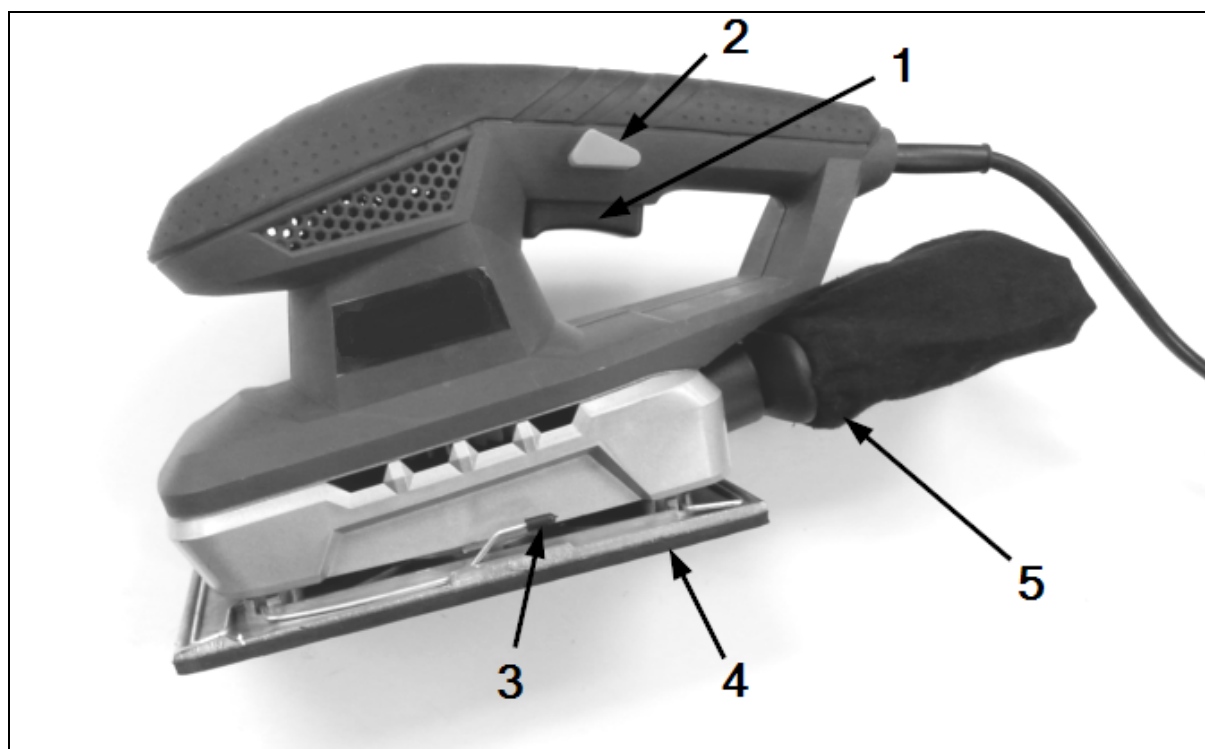

1. On/Off Switch
2. Lock On Button
3. Sandpaper Clamp Lever
4. Base Pad
5. Dust Collection Box

**Dear Valued Customer,**

Thank you for purchasing this Mako Power Tool.

We are dedicated to providing quality Mako Power Tools at competitive prices. Whether you are serious about DIY or just a casual user, our range of power tools are perfect for any job.

**Mako 2 Year DIY Warranty:**

All Mako Power Tools are backed by a comprehensive 2 year DIY warranty. If for any reason you experience a fault with this power tool, please contact the retailer that it was purchased from, present the receipt and warranty card (at the back of the operating manual), for a full refund or replacement. The warranty is void if damage is not attributable to normal wear and tear, if the tool is used commercially, the motor is overloaded or is tampered with, is damaged by accident or if it is bought second hand. Continued use after partial failure, or the use with the incorrect accessories will void the warranty.

This warranty excludes all Mako accessories, which are covered by their own appropriate warranties.

**MAKO TOOLS ARE FOR DIY USE ONLY. THEY ARE NOT DESIGNED OR APPROVED FOR INDUSTRIAL OR COMMERCIAL USE.**









## CONTENTS:

- **General Safety Rules**
  - **Work Area safety**
  - **Electrical Safety**
  - **Personal Safety**
  - **Power Tool Use and Care**
  - **Service**
- **Mako Finishing Sander Safety Instructions**
- **Mako Finishing Sander Operating Instructions**
- **Maintenance & Cleaning**
- **Mako Finishing Sander Technical Data**

## DESCRIPTION OF SYMBOLS:



Please read all of the safety and operating instructions carefully before using this sander. Please pay particular attention to all sections of this User Guide that carry warning symbols and notices.

	Observe caution and safety notes!
	Caution- electric shock! Danger to life!
$n_0$	No-load speed.
V~	AC Voltage
	Wear hearing protection, dust protection mask, protective glasses and protective gloves.
	Keep children away from electrical power tools!
	Only for use in dry, indoor spaces.
	Check that the device, mains lead and plug are in good condition!
	Safety class II
	Dispose of packaging and appliance in an environmentally friendly way!

## GENERAL POWER TOOL SAFETY WARNINGS



**WARNING** Read all safety warnings and all instructions. Failure to follow the warnings and instructions may result in electric shock, fire and/or serious injury. Read all warnings and instructions for future reference. The term "power tool" in the warnings refers to your mains-operated (corded) power tool or battery-operated (cordless) power tool.

### 1) Work area safety

- a) **Keep work area clean and well lit.** Cluttered or dark areas invite accidents.
- b) **Do not operate power tools in explosive atmospheres, such as in the presence of flammable liquids, gases or dust.** Power tools create sparks which may ignite the dust or fumes.
- c) **Keep children and bystanders away while operating a power tool.** Distractions can cause you to lose control.

### 2) Electrical safety

- a) **Power tool plugs must match the outlet. Never modify the plug in any way. Do not use any adapter plugs with earthed (grounded) power tools.** Unmodified plugs and matching outlets will reduce risk of electric shock.
- b) **Avoid body contact with earthed or grounded surfaces, such as pipes, radiators, ranges and refrigerators.** There is an increased risk of electric shock if your body is earthed or grounded.
- c) **Do not expose power tools to rain or wet conditions.** Water entering a power tool will increase the risk of electric shock.
- d) **Do not abuse the cord. Never use the cord for carrying, pulling or unplugging the power tool. Keep cord away from heat, oil, sharp edges or moving parts.** Damaged or entangled cords increase the risk of electric shock.
- e) **When operating a power tool outdoors, use an extension cord suitable for outdoor use.** Use of a cord suitable for outdoor use reduces the risk of electric shock.
- f) **If operating a power tool in a damp location is unavoidable, use a residual current device (RCD) protected supply.** Use of an RCD reduces the risk of electric shock.

### 3) Personal safety

- a) **Stay alert, watch what you are doing and use common sense when operating a power tool. Do not use a power tool while you are tired or under the influence of drugs, alcohol or medication.** A moment of inattention while operating power tools may result in serious personal injury.
- b) **Use personal protective equipment. Always wear eye protection.** Protective equipment such as dust mask, non-skid safety shoes, hard hat, or hearing protection used for appropriate conditions will reduce personal injuries.
- c) **Prevent unintentional starting. Ensure the switch is in the off-position before connecting to power source and/or battery pack, picking up or carrying the tool.** Carrying power tools with your finger on the switch or energising power tools that have the switch on invites accidents.
- d) **Remove any adjusting key or wrench before turning the power tool on.** A wrench or a key left attached to a rotating part of the power tool may result in personal injury.
- e) **Do not overreach. Keep proper footing and balance at all times.** This enables better control of the power tool in unexpected situations.
- f) **Dress properly. Do not wear loose clothing or jewelry. Keep your hair, clothing and gloves away from moving parts.** Loose clothes, jewelry or long hair can be caught in moving parts.
- g) **If devices are provided for the connection of dust extraction and collection facilities, ensure these are connected and properly used.** Use of dust collection can reduce dust-related hazards.

### 4) Power tool use and care

- a) **Do not force the power tool. Use the correct power tool for your application.** The correct power tool will do the job better and safer at the rate for which it was designed.

- b) **Do not use the power tool if the switch does not turn it on and off.** *Any power tool that cannot be controlled with the switch is dangerous and must be repaired.*
- c) **Disconnect the plug from the power source and/or the battery pack from the power tool before making any adjustments, changing accessories, or storing power tools.** *Such preventive safety measures reduce the risk of starting the power tool accidentally.*
- d) **Store idle power tools out of the reach of children and do not allow persons unfamiliar with the power tool or these instructions to operate the power tool.** *Power tools are dangerous in the hands of untrained users.*
- e) **Maintain power tools. Check for misalignment or binding of moving parts, breakage of parts and any other condition that may affect the power tool's operation. If damaged, have the power tool repaired before use.** *Many accidents are caused by poorly maintained power tools.*
- f) **Keep cutting tools sharp and clean.** *Properly maintained cutting tools with sharp cutting edges are less likely to bind and are easier to control.*
- g) **Use the power tool, accessories and tool bits etc. in accordance with these instructions, taking into account the working conditions and the work to be performed.** *Use of the power tool for operations different from those intended could result in a hazardous situation.*

#### 5) Service

**Have your power tool serviced by a qualified repair person using only identical replacement parts.** *This will ensure that the safety of the power tool is maintained.*

### MAKO FINISHING SANDER SAFETY INSTRUCTIONS:



**WARNING!** A suitable breathing respirator must be worn while sanding lead painted surfaces, woods and metals to avoid breathing the potentially harmful/toxic dust or air. Contact with or inhalation of these dusts can endanger the health of operator and bystanders.

Always wear safety goggles and a dust mask when sanding, especially when sanding over-head.

**Do not use sand paper larger than needed.** Extra paper extending beyond the sanding pad dimensions can cause serious lacerations.

**Caution, fire hazard!** Avoid overheating the material being sanded as well as the Sander, by the keeping the Sander constantly moving.

**Ensure the dust collection bag is cleared regularly.** This will reduce the chance of material igniting, especially when sanding metal objects

**When working with the Sander, always hold it firmly with both hands.** The power tool is guided more securely with both hands, giving better results.

**Always ensure the material you are sanding is securely fastened.** Where necessary, ensure that the material is clamped or held in a vice.

**If the supply cord is damaged it must be replaced only with the correct part by an authorised service agent to avoid a safety hazard.**



**WARNING!** Do not throw sanding dust on an open fire because materials in fine particle form may be explosive.

## MAKO FINISHING SANDER OPERATING INSTRUCTIONS:



**Read all safety warnings and all instructions.** Failure to follow the warnings and instructions may result in electric shock, fire and/or serious injury.



**WARNING: Some dust created by power sanding, sawing, grinding, drilling, and other construction activities contains chemicals known to cause cancer, birth defects or other reproductive harm. Some examples of these chemicals are:**

- Lead from lead-based paints,
- Crystalline silica from bricks and cement and other masonry products, and
- Arsenic and chromium from chemically treated lumber.

Your risk from these exposures varies, depending on how often you do this type of work. To reduce your exposure to these chemicals: work in a well ventilated area, and work with approved safety equipment, such as those dust masks that are specially designed to filter out microscopic particles.

The machine is intended for dry sanding of wood, plastic, metal filler as well as coated surfaces. The Mako Finishing Sander is approved solely for private use in dry areas. Any other use or modification of this Sander constitutes improper use and poses a serious risk of accident. The manufacturer is not liable for damage caused by improper use of the tool.

**It is recommended that the tool always be supplied via a residual current device with a rated current of 30mA or less.**

### Choosing the right grade of sandpaper:



**WARNING:** Always ensure that the tool is switched off and the plug is removed from the power outlet before making any adjustments or maintenance procedures.

The various grades of sandpaper can be purchased from your local hardware store. Please seek advice on the best grade for your job.

Use a coarser grit to sand down rough finishes, medium grit to smooth the work and fine grit to finish off.

It is best to conduct a trial on a piece of material to be sanded, to determine the correct grades of sandpaper for the particular job. If there are still marks on the surface after sanding, try either going back to a coarser grade and sanding the marks out before recommencing with the original choice of grit, or if this doesn't work, try using a new piece of sandpaper to eliminate the unwanted marks before going on to a finer grit and finishing the job.



**WARNING** Do not use the same sanding sheet for wood and metal. Metal particles become embed in the sandpaper and will scour a wooden surface.

### Fitting the sandpaper:

Your sander uses one third sheets of standard sandpaper, or pre-cut punched hook and loop backed sheets.

#### Sanding sheets without hook and loop fastening:

Disconnect the plug from the electricity supply.

Press the handles of the front and rear paper clamp (5) upwards, to release them from their retaining mounts.

Align the holes in the sandpaper (6) with the dust extraction holes in the base of your sander.

Hold the sandpaper in position and insert the edge of the sandpaper under the front paper clamp.

Press the handle of the paper clamp downwards and lock it in the retaining mount.

Keeping the sand paper tight - insert the rear edge of the sand paper in the rear paper clamp. Press the handle of the paper clamp downwards and lock it in the retaining mount.

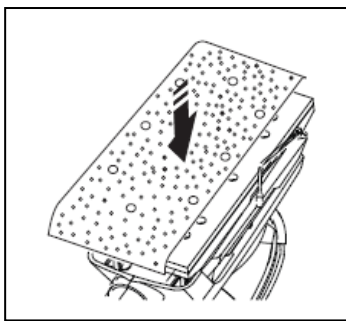
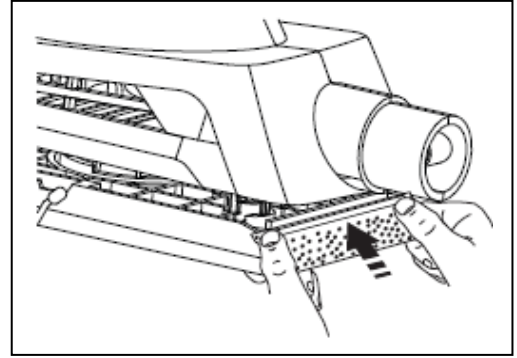
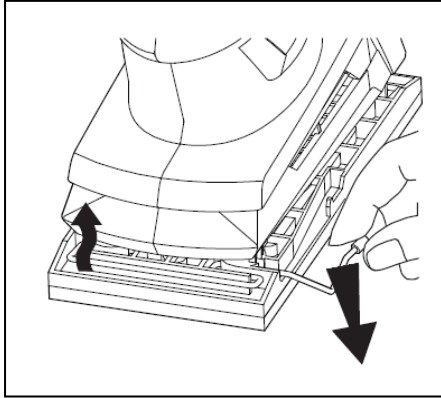

#### **Sanding sheets with hook and loop fastening:**

Align one side of the sandpaper flush with one side of the Backing Pad (6) then attach the sandpaper to the Backing Pad and press it firmly into place. Ensure the holes in the paper align with the holes in the Backing Pad for efficient dust extraction.

#### **Connecting the dust box:**

To connect the Dust Collection Bag, push it firmly into the socket at the rear of the sander. To remove the Dust Collection Bag, twist and pull it out of the socket.

To remove the bag from the holder for easy emptying, pull the elasticated top of the bag out of the groove on the holder.

#### **Switching On and Off:**

Plug the power cord into the power outlet.

To start the Sander, press the ON/OFF switch (2).

To stop the Sander, release the ON/OFF switch (2).

To lock the ON/OFF switch, press the switch and push in the lock-on button (1).

Press the ON/OFF switch (2) to release the lock.

The required sanding rate will depend on the material you are working on. After longer periods of use at a low sanding rate, allow the machine to cool down by running it for approximately **3 minutes** at the maximum speed with no load.

Wait until the Sander has come to a complete stop before placing it down on a bench or other surface.

#### **Sanding Surfaces:**

Turn the Finishing Sander on, place it with the full pad area on the surface to be sanded, and move it with moderate pressure over the surface.

The amount of material removed is determined by the grade of the sand paper chosen, sanding rate and the pressure applied. For best results, and to extend the life of the Finishing Sander, always use brand new sand paper.

Applying increased pressure to the Finishing Sander does not lead to an increase in the sanding rate, but instead increases the wear on the sand paper.

Only use the original accessories included in this Finishing Sander.



**Rough Sanding:**

Attach coarse grade sand paper. Apply only light pressure to the Finishing Sander so that it runs at a higher sanding rate, achieving a high rate of removal.

**Fine Sanding:**

Attach fine grade sand paper. Vary the amount of pressure applied to the Finishing Sander, and/or alter the sanding rate to achieve the best results.

**MAINTENANCE AND CLEANING:**

Before any work commences on the Finishing Sander, ensure that it is unplugged from the power outlet.

For optimum use, regularly check to see if any dust or foreign matter has entered the ventilations slots near the motor and around the on/off switch. Use a soft brush if required. Wear safety glasses to protect your eyes whilst cleaning.

If the body of the tool needs cleaning, wipe it with a soft damp cloth. A mild detergent can be used, but not alcohol-based, petrol, or other cleaning agents.

Never use caustic agents to clean plastic parts.

Lubricate all moving parts at regular intervals.



**CAUTION** Water must never come into contact with this tool.

**DISPOSAL**

**Do not dispose of electrical appliances with your domestic waste!** The packaging comprises exclusively environmentally- friendly material. Dispose of it in your local recycling containers.

**TECHNICAL DATA**

FINISHING SANDER	SROM1185
Voltage rating	AC 230-240V,50Hz
Power rating	200W
No-load speed $n_o$	11000 min <sup>-1</sup>
Sanding pad size	92mm x 185mm (1/3 sheet)